

Absolute Process Instruments, Inc.

Manufacturer of Quality Signal Conditioners Transmitters & Isolators

Application Notes

- General Info
- Temperature
- Pressure
- Flow
- Speed
- Weighing
- Process

Fail Safe Valve Control

PROBLEM

For safety reasons an automated normally closed valve used in a coal mining operation must go to the full open position if the control signal from the programmable logic controller (PLC) is lost.

SOLUTION

The valve is controlled by an API 3200 G Valve/Actuator Positioner/Controller module. The input to the API 3200 G comes through an API 1000 G DC Input Single Alarm Trip module, which selects either the PLC output or a constant 20 mA output from an API 4003 GIS DC Special Transmitter module.

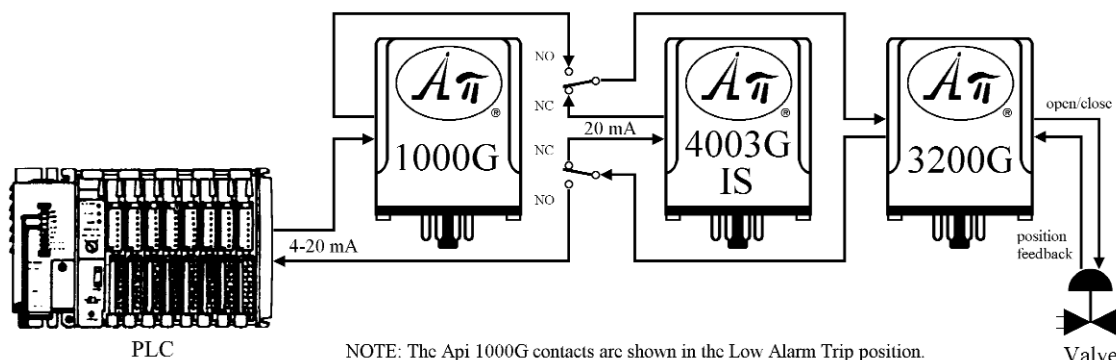

If the signal from the PLC drops below 4 mA, the API 1000 G will trip to a low alarm state, and select the 20 mA signal for the API 3200 G, thus commanding the valve to open fully. When the signal from the PLC is 4 mA or greater, the API 1000 G selects the PLC output signal for the API 3200 G, thus controlling valve position as normal.

Did You Know...?

Api can do input to output reversals on our transmitters.

FREE APPLICATION ASSISTANCE
 Call **Customer Service**
800-942-0315